

Drehstrommotor / Three-Phase Motor

IE4 - 90 kW - 6 polig / 6 pole - B3

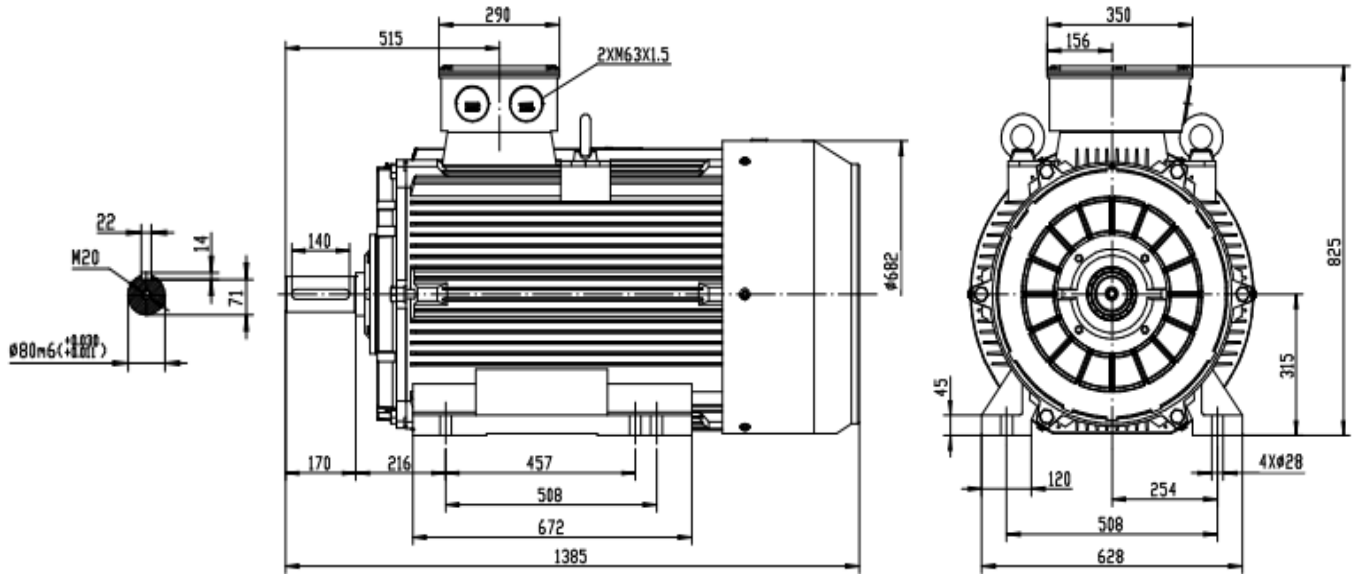

Typ / type

IE4 SEV- 315M-6

| | | |
|-------------------------------------|------------------|---|
| Gehäusematerial / frame material | | Grauguss / cast iron |
| Ausführung / execution | | Dreiphasen/ three phase |
| Baugröße / frame size | | 315 |
| Leistung / power @50Hz | kW | 90,00 |
| Nennstrom / rated current @400V | Δ | 159,86 |
| Nennstrom / rated current @690V | Y | 92,67 |
| Drehzahl / speed @50Hz | Upm / rpm | 990 |
| Wirkungsgrad / efficiency | IE4 | |
| | Eff. 100% | 95,60 |
| | Eff. 75% | 95,80 |
| | Eff. 50% | 95,40 |
| Leistungsfaktor / power factor cosφ | Last / load 100% | 0,85 |
| 60Hz 460/793V | Power(kW) | 103,50 |
| 60Hz 480/830V | Power(kW) | 108,00 |
| Drehzahl / speed @60Hz | (r/min) | 1188 |
| Normen / regulations | | IEC / DIN / ISO / VDE / EN |
| Standard / standard | | IEC 60034 |
| Umgebungstemperatur / ambient Temp. | | -20°C ~ +40°C |
| Aufstellungshöhe / altitude (max.) | | 1000m über Meerespiegel / above sea level |

| | |
|--|---|
| Nenn Drehmoment / rated torque | 868,60 |
| Anzugs- zu Nennmoment / start- to rated torque | 1,6 |
| Kipp- zu Nennmoment / brakedown- to rated torque | 2 |
| min. Dreh- zu Nennmoment / min- to rated torque | 1 |
| Anzugs- zu Nennstrom / starting- to rated current | 8 |
| Lager / bearing (DE) | NU319 |
| Lager / bearing (NDE) | 6317C3 |
| Wellendichtung / shaft seal (DE/NDE) | 95*120*12 |
| Hauptkabelverschraubung / main cable glands | 2-M63*1.5 |
| Isolationsklasse / insulation class | F |
| Schutzart / protection degree | IP 55 |
| Thermischer Schutz / thermal protection | 3*PTC |
| Drehrichtung / rotation direction | rechts-links / clockwise-counterclockwise |
| Einschaltdauer / service duty | S1 |
| Wuchtung / balance | Halbkeilwuchtung / half-key balanced |
| Kühlungsart / cooling | IC 411 |
| Lautstärke / noise dB(A) | 83 |
| Nettogewicht / net weight(kg) | 922,00 |
| Massenträgheitsmoment / moment of inertia (kg*m ²) | 5,257374608 |